

REV.	DESCRIPTION	DATE
A	RELEASED	2019/04/15

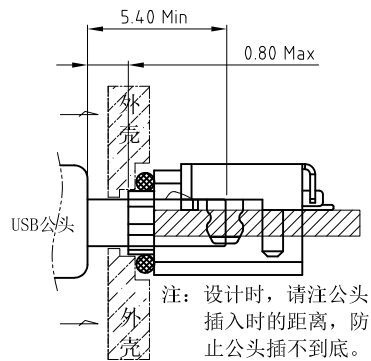

注：设计时，请注公头插入时的距离，防止公头插不到底。

组装示意图

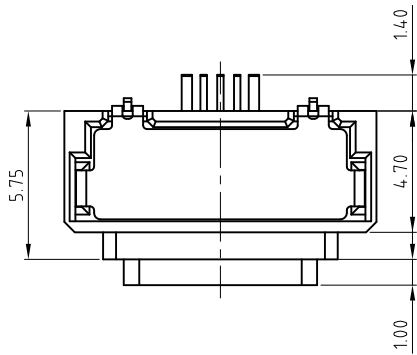
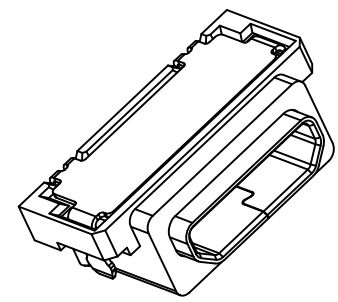

- SPECIFICATIONS:
- ELECTRICAL CHARACTERISTICS:
 - RATING: 3A(PIN1&5),0.5A(PIN2&3&4);
 - CONTACT RESISTANCE: 30 mΩ MAX.(INITIAL);
 - DIELECTRIC WITHSTANDING: 500V AC MIN.;
 - INSULATION RESISTANCE: 1000MΩ MIN.;
 - DURABILITY: 5,000 CYCLES MIN.;
 - INSERTION FORCE: 3.5Kgf (35N) Max.;
 - EXTRACTION FORCE: 0.8Kgf (8N) Min.;
 - WATER PROOFNESS: THIS PRODUCT IS BASED ON IPX7.
 - PLUG INTERFACE DIMENSIONS COMFORM TO USB2.0 SPEC.
 - PACKAGING: TAPE & REEL.

PART NUMBER INFORMATION :

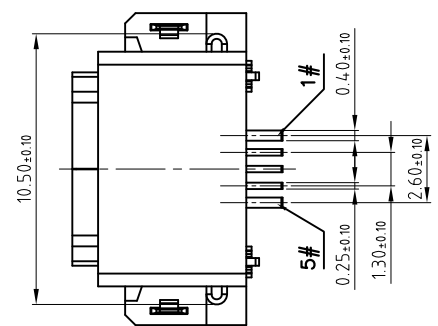
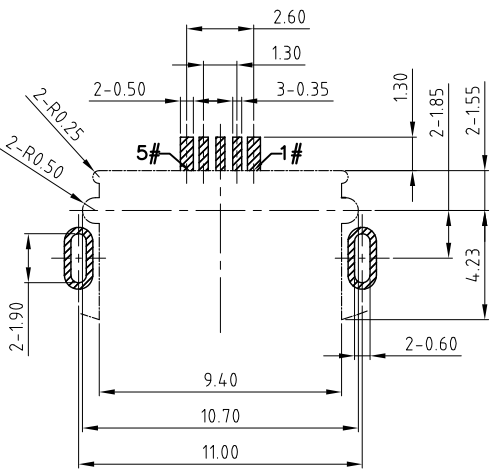
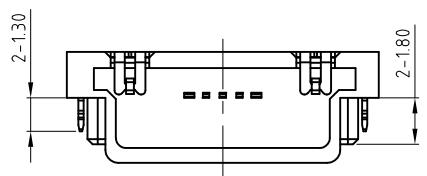
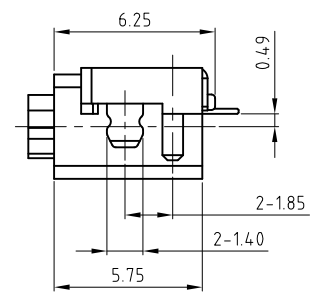
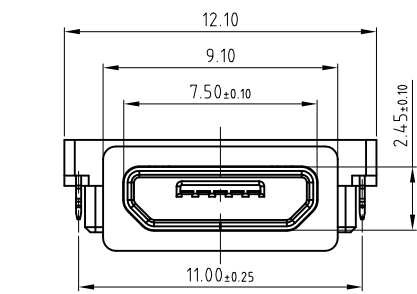
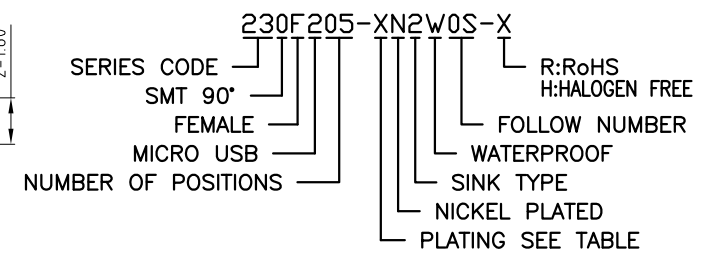

RECOMMEND PCB LAYOUT
TOLERANCE: ±0.05
TOP VIEW

Contact Number	Signal Name	Remarks
1#	VBUS	Power
2#	D-	Date-
3#	D+	Date+
4#	ID	Reserve or Ground
5#	GND	Ground

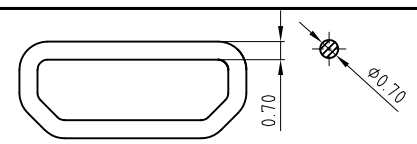

注：防水圈是圆形截面，直径为0.7mm的硅胶圈。
防水圈挤压量，由0.7mm挤压到0.3mm ~ 0.4mm，防水效果好。

3	Shell	1	SUS304R-1/2H Ni PlatingT=0.30mm				
2	Contact	5	Phosphor bronze C5191R-EH Au/Ni Plating T=0.20mm				
1	Housing	1	PA9T&LCP (G.F30%)				
ITEM	PART NAME	Q'TY	FINISH	NOTE			
DESCRIPTION OF PLATING ON TERMINALS							
NO.	EXPLAIN		NO.	EXPLAIN			
0	GOLD FLASH		3	GOLD 15u"			
1	GOLD 5u"		4	GOLD 20u"			
2	GOLD 10u"		6	GOLD 30u"			
TOLERANCE		DRAWER		INMO 东莞市英墨电子有限公司 INMO Electronics Co.,Ltd NAME MICRO USB 5P L6.75 沉板 2.5 WATERPROOF DRAW NO. R230F205-XN2W0S-X			
.0=±0.35		*****					
.00=±0.25		CHECK					
.000=±0.05		APP'D					
ANG.=±3°		PRODUCT SPEC.					
		UNITS : mm					
SCALE	NONE	SIZE	A4	SHEET	1 OF 1	REV.	*